

Parallel Shaft Helical Gear Box

G
GEAR'S

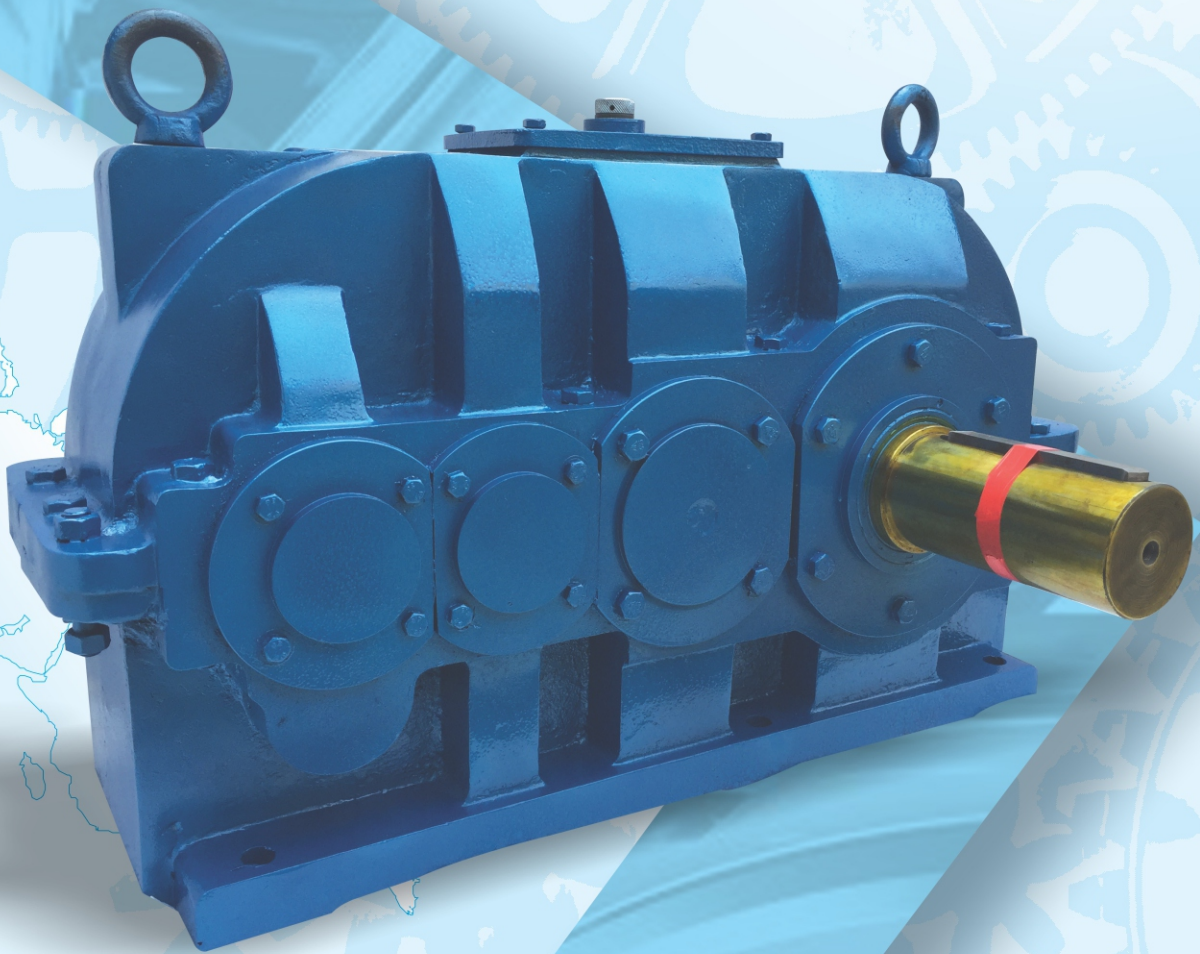

*Drive it,
Believe it !*

Selection of PRL Series gear units

1. Determine the transmission ratio

$$i_N = \frac{n_1}{n_2}$$

The type of gear is then determined

2. Determination of the gear size

- 2.1 Finding out gear box size

$$P_N \stackrel{3}{\geq} P_e \times f \quad 'f' \text{ from tables 1,2 and 4}$$

- 2.2 Checking starting torque

$$\frac{M_k \cdot n_1}{P_N \cdot 955} \stackrel{\leq}{\leq} 2.5$$

3. Checking heating effects

- 3.1 Gear unit without additional cooling when

$$P_e \stackrel{\leq}{\leq} P_{G1} \times f_w$$

- 3.2 Gear unit with fan possible when

$$P_e \stackrel{\leq}{\leq} P_{G2} \times f_w$$

- 3.3 Gear unit with built-in cooling coil possible when

$$P_e \stackrel{\leq}{\leq} P_{G3} \times f_w$$

- 3.4 Gear unit with built-in cooling coil and fan possible when

$$P_e \stackrel{\leq}{\leq} P_{G4} \times f_w$$

- 3.5 Gear unit with external oil cooler necessary when

$$P_e \stackrel{3}{\geq} P_{G4} \times f_w$$

i_N = nominal transmission ratio

n_1 = input speed [rpm];

n_2 = output speed [rpm];

P_N = nominal gear box rating [kw] - see power table

P_e = absorbed power of the connected machine [kw]

f = service factor = $f_1 \times f_2$

f_w = factor for amb. temperatures (table 3)

t = ambient temperature [° C]

E_D = running period [%], e.g. $E_D = 80\%$

P_{G1} = Thermal capacity without additional cooling at $t=20^\circ \text{C}$; $E_D = 100$ (see power table)

P_{G2} = Thermal capacity with fan

P_{G3} = Thermal capacity with built-in cooling coil

P_{G4} = Thermal capacity with built-in cooling coil and fan

M_k = Starting torque or max. input torque [da Nm]

Example of calculation

Given

Prime mover :

electric motor, $P_{\text{motor}} = 1000[\text{kW}]$; $n_1 = 1500$ [rpm];
2 fold starting torque $M_k = 1273$ [da Nm]

Working machine :

Heavy rubber-belt conveyor

Power demand : $P_e = 950$ [kW]

Speed : $n_2 = 60$ [rpm];

Period of operation : 16 hours per day

Starts : 1 per hour

Running duration per hour : $E_D = 100$ [%]

Ambient temperature : 40 [° C]

Required :

Type and size of gear box

Design :

$$1. \quad i_N = \frac{n_1}{n_2} = \frac{1500}{60} \quad \Omega \quad 25:1$$

Selected : Gear box type GHC, triple reduction helical gears.

2. Determination of gear box size

- 2.1 Operating factor : 'f' from tables 1 and 2 = 1.50

- 2.2 Required nominal gear box rating :

$$P_N = P_e \times f = 950 [\text{kW}] \times 1.5 = 1425 [\text{kW}]$$

- 2.3 From power table select GHC gear box size 560 with $P_N = 1460$ [kW]

- 2.4 $P_N \stackrel{3}{\geq} P_e \times f$, as $1460 [\text{kW}] \stackrel{3}{\geq} 950 [\text{kW}] \times 1.5 = 1425 [\text{kW}]$

- 2.5 Checking starting torque

$$\frac{M_k \cdot n_1}{P_N \cdot 955} \stackrel{\leq}{\leq} 2.5 = \frac{1273 [\text{da Nm}] \cdot 1500 [\text{rpm}]}{1460 [\text{kW}] \cdot 955} = 1.37$$

3. Check for heating

- 3.1 From table 3

$f_w = 0.75$ for gear unit without additional cooling

$P_e \stackrel{3}{\geq} P_{G1} \times f_w$, as $950 [\text{kW}] \stackrel{3}{\geq} 485 [\text{kW}] \times 0.75 = 364 [\text{kW}]$, i.e., additional cooling is required.

- 3.2 From table 3

$f_w = 0.8$ for gear unit with fan cooling

$P_e \stackrel{3}{\geq} P_{G2} \times f_w$, as $950 [\text{kW}] \stackrel{3}{\geq} 1160 [\text{kW}] \times 0.8 = 928 [\text{kW}]$, i.e., fan cooling is not sufficient.

- 3.3 From table 3

$f_w = 0.85$ for gear unit with cooling coil

$P_e \stackrel{3}{\geq} P_{G3} \times f_w$, as $950 [\text{kW}] \stackrel{3}{\geq} 685 [\text{kW}] \times 0.85 = 582 [\text{kW}]$ i.e., a cooling coil is not sufficient.

- 3.4 From table 3

$f_w = 0.83$ for gear unit with fan and additional cooling coil

$P_e \stackrel{\leq}{\leq} P_{G4} \times f_w$, as $950 [\text{kW}] \stackrel{\leq}{\leq} 1360 [\text{kW}] \times 0.83 = 1129 [\text{kW}]$

- 3.5 The GHC 560 gear unit, $i_N = 25:1$ requires fan and cooling coil.

Operating factors

Table 1		Load parameters			
Driven machines		Driven machines		Driven machines	
Excavators and stackers		Impeller blowers	G	-- wet	S**
Bucket chain excavators	S*	Turbo blowers	G	-- suction	S**
Travelling gear		Centrifugal blowers	G	Suction rollers	S**
--- caterpillar track	S*	Generators		Drying cylinders	S**
--- rail	M	Generators, under uniform load	G	Pumps	
Bucket-wheel stackers	M*	Welding generators	***	Proportioning pumps	M
Bucket wheels		Rubber and Plastics		Piston pumps	
--- clearing	S	Extruders		- U ■ 1:100	S
--- coal	S	-- rubber	S**	- U ■ 1:100 - 1:200	M**
--- lime	S	-- plastics	M**	Centrifugal pumps	
Cutter heads	S*	Calenders	M**	- light liquids	G
Slewing machines	M*	Kneading machines, rubber	S**	- viscous liquids	M
Suction pumps	M*	Mixers	M**	Compression pumps	S
Cable drums	M	Mills, rubber	M**	Plunger pumps	S**
Winches	M	Rolling mills, rubber	S**	Sand pumps	M**
Mining, rock, earth		Wood-working machinery		Machines for the Textile Industry	
Concrete mixers	M	Decorticating drums	S	Bobbin winding machines	M
Crushers	S	Planing machine	M	Printing machines	M
Briquetting presses	H	Saw frames	M	Dyeing machines	M
Rotary kilns	S**	Iron and Steel Industry		Tan-liquor vessels	M
Pneumatic sifters	M*	Foundry crane (hoisting gear)	S**	Calenders	M
Clay mixers	M	Converters	***	Willowing machines	M
Chemical Industry		Slag cars	G**	Drying machines	M
Mixers	M	Sintering belts	M**	Looms	M
Agitators		Crusher	S**	Compressors	
--- pure liquids	G	Torpedo mixers	***	Rotary piston compressors	
--- liquids and solids	M	Car tipper	S	- U ■ 1:100	S
--- liquids with various densities	M	Cranes		- U ■ 1:100 - 1:200	M
Rotary Dryer	M	Luffing gear	G*	Centrifugal compressors	M
Centrifuges		Travelling gear	M*	Turbo compressors	M
--- light	G	Hoisting gear	M*	Rolling mills	
--- heavy	M	Slewing gear	M*	Plate tilters	M**
Petroleum Industry		Winches	G	Bloom pushers	H**
Drilling pumps	***	Metal working		Bloom conveying plant	S**
Rotary Kilns	M	Folding presses	S	Wire pulls	M
Filter presses	M**	Plate bending machines	M**	Revolving turrets	M**
Pipeline pumps	M**	Plate straightening presses	S	(contin. casting)	
Scavenging pumps	M**	Eccentric presses	S	De-scaling crushers	S**
Conveying plants		Hammers	S**	Reels	
Uniform load		Planing machines	S	- strip	M*
Bucket conveyors	G	Crank presses	S	- wire	M**
Roasting furnace conveyors	G	Shearing machine	M**	Walking beam conveyors	M*
Assembly line belts	G	Forging presses	S	Chain transporter	M**
Band conveyors	G	Punching machines	S	Cooling troughs	M**
Overhead conveyors	G	Mills		Traverse tractors	M**
Chain conveyors	G	Hammer mills	H**	Pipe welding machine	S
Apron conveyors	G	Edge mills	H**	Pipe drawing machine	S*
Worm conveyors	G	Ball mills	H**	Roller strightening machine	M**
Medium and heavy load		Pendulum mills	H**	Roller gear beds	
Shaft - sinking machines	S*	Impact mills	H**	--- light	M**
Bucket conveyors	M	Tube mills	H**	--- heavy	S**
Bucket belts	M**	Beating mills	H**	Shears	
Assembly line conveyors	M	Rod mills	H**	--- plate	S**
Conveyors winders	M**	Roller mills	H**	--- wire	M**
Conveyors	S*	Foodstuffs machines		--- billet	S**
Belt Conveyors	M	Filling machines	G	--- cropping	S**
Chain Conveyors	M	Kneading machines	M	--- plate trimming	M**
Goods lifts	M	Packing machines	G	Winding turret	M**
Passenger lifts	***	Weighing machines	M	Winding tractor	M**
Apron conveyors	M	Sugarcane crushers	M**	Continuous casting plants	S**
Shaker conveyors	M	Sugarcane mills	S**	Shifting device	S
Worm conveyors	M	Sugarcane Cutters	M**	Roller adjusting device	M
Inclined lifts	S**	Sugar-beet Cutters	M	Water recycling machine	
Blowers, fans, ventilators		Paper machines		Thickeners	M
Axial blowers	M	Couchers	S**	Gyroscopic ventilators	M
Rotary piston blowers	M	Glazing cylinders	S**	Mixers	M
Large ventilators (mining)	M	Calenders	M**	Water screws	M
Cooling tower fans	***	Mixers	M	Vacuum filter presses	M
Radial blowers	M	Presses		Rate/Screen drives	G
Induced draft fans	M	-- glue	S**		

Table 2		Service factor			f ₁	
Prime mover	Hours of operation/day	Prime mover Load parameter			Extra Heavy duty H	
		Uniform load G	Medium load M	Heavy load S		
Electric motor turbine	up to 3	0.80	1.00	1.50	2.0	
	over 3 to 10	1.00	1.25	1.75	2.25	
Piston engines 4-6 cylinder U ■ 1:100-1:200	up to 3	1.00	1.25	1.75	2.25	
	over 3 to 10	1.25	1.50	2.00	2.5	
Piston engines 1-3 cylinder U ■ 1:100	up to 3	1.25	1.50	2.00	2.5	
	over 3 to 10	1.50	1.75	2.25	2.75	

1) Cooling water temperature max. 20° C

Load parameters

G = Uniform load

M = Medium load

S = Heavy load

H = Extra Heavy duty

* = Detailed calculation on request

** = Only calculated for 24-hour period of operation

*** = Load parameter on request.

U = Cyclic variation

The load parameters quoted are parameters gained from experience. Calculations for driven machines not mentioned above or deviations from the norm obtainable on request.

Table 3		Factor for amb. temperatures					f _w
Type of cooling	Ambient temperature	Duration of operation per hour					
		100%	80%	60%	40%	20%	
For gear boxes	10° C	1.12	1.34	1.57	1.79	2.05	
	20° C	1.0	1.2	1.4	1.6	1.8	
without additional cooling	30° C	0.88	1.06	1.23	1.41	1.58	
	40° C	0.75	0.9	1.05	1.2	1.35	
For gear boxes with fans	50° C	0.63	0.76	0.88	1.01	1.13	
	10° C	1.15	1.38	1.61	1.84	2.07	
without additional cooling	20° C	1.0	1.2	1.4	1.6	1.8	
	30° C	0.9	1.08	1.26	1.44	1.62	
For gear boxes with fans and cooling coils	40° C	0.8	0.96	1.12	1.29	1.44	
	50° C	0.7	0.84	0.98	1.12	1.26	
For gear boxes with fans and cooling coils	10° C	1.1	1.32	1.54	1.76	1.98	
	20° C	1.0	1.2	1.4	1.6	1.8	
without additional cooling	30° C	0.9	1.08	1.26	1.44	1.62	
	40° C	0.85	1.02	1.19	1.36	1.53	
For gear boxes with fans and cooling coils	50° C	0.8	0.96	1.12	1.29	1.44	
	10° C	1.12	1.34	1.57	1.79	2.05	
without additional cooling	20° C	1.0	1.2	1.4	1.6	1.8	
	30° C	0.92	1.1	1.29	1.47	1.66	
For gear boxes with fans and cooling coils	40° C	0.83	1.0	1.16	1.33	1.5	
	50° C	0.78	0.94	1.09	1.25	1.4	

1) Maximum cooling-water temperature 20° C

Table 4		Starting-frequency factor						f ₂
Starts per hour		Driven machines factor						
		1.2	1.2	1.4	1.6	1.8	2.0	
1		1	1	1	1	1	1	
2 to 20		1.2	1.1	1.08	1.07	1.07	1.06	
21 to 40		1.3	1.2	1.17	1.16	1.15	1.08	
41 to 80		1.5	1.4	1.25	1.23	1.18	1.10	
81 to 160		1.6	1.5	1.35	1.3	1.2	1.1	
160 to 320		2	1.8	1.7	1.6	1.5	1.4	
Over 320		2.5	2.25	2	1.9	1.8	1.75	

Two Stage Helical Gear Units - GHB

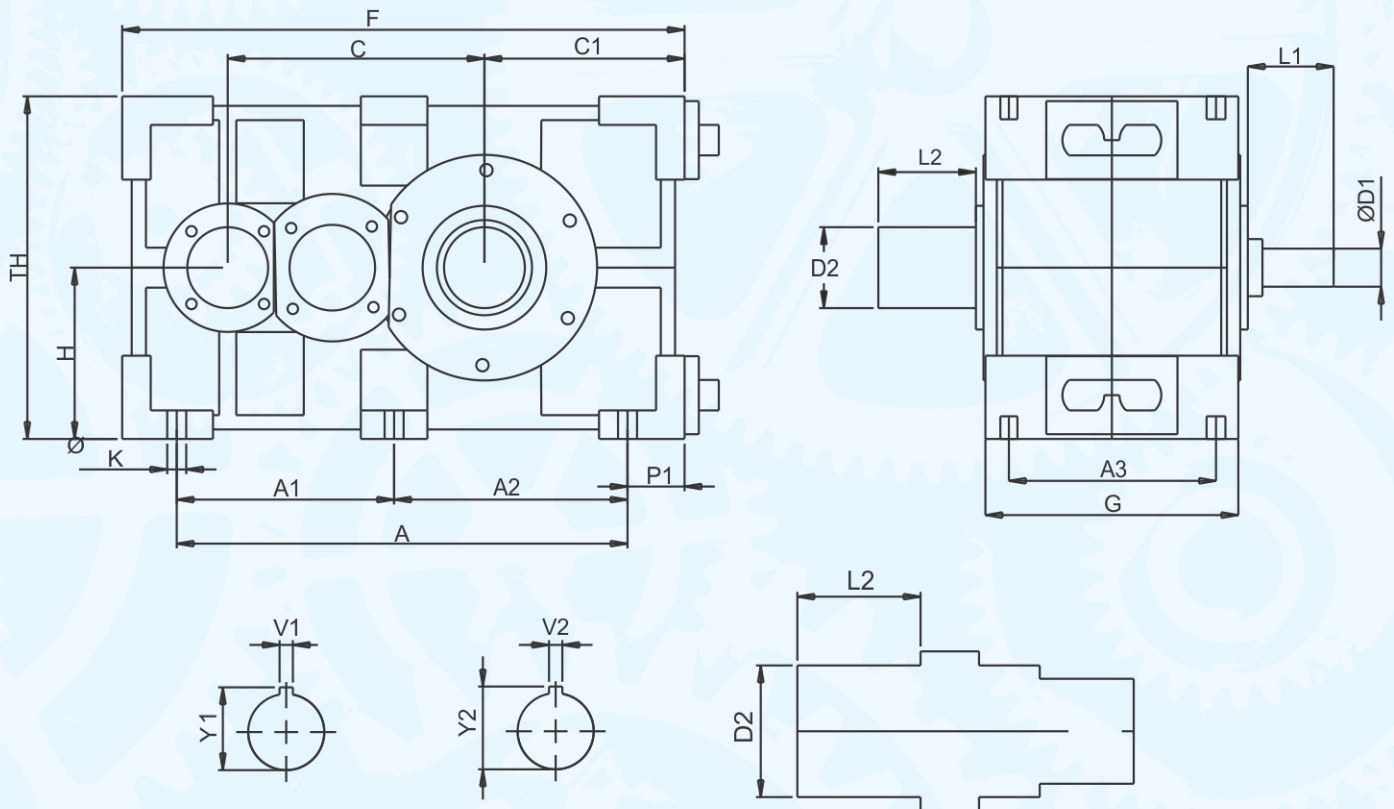

TYPE	INPUT SHAFT				OUTPUT SHAFT				OIL
	D1	L2	V1	Y1	D2	L2	V2	Y2	
110	25	60	8	28	45	100	14	50	5
125	30	80	8	33	55	110	16	60	7
140	35	80	10	38.5	65	130	18	70	10
160	40	100	12	43	75	140	20	81	15
180	50	110	14	53.5	95	160	25	102	20

GEAR BOX HOUSING DIMENSION												
TYPE	C	C1	A	A1	A2	A3	P1	G	H	TH	F	K
110	190	150	328	-	-	149	47	210	125	249	420	14
125	215	160	365	-	-	173	52	223	143	285	461	16
140	240	177	431	-	-	195	49	238	156	312	535	18
160	270	207	468	222	246	221	62	269	181	361	600	20
180	305	235	531	264	266	233	74	285	210	420	685	22

Nominal Transmission ratio i_n	Nominal Speeds [rpm] n_1, n_2		Size of gear unit																	
			110	125	140	160	180	200	225	250	280	315	355	400	450	500	560	630	710	800
6.3	1500	240	36	50	70	105	145	205	285	370	530	790	790	1450*	2020*	3740*	3740*	7020*		
	1000	160	24	34	47	71	100	145	215	280	400	560	560	1100	1520	2650	2650	4780*	7120*	
	750	120	18	25	36	54	74	100	110	170	230	310	425	425	900	1200	1990	1990	3600	5420*
7.1	1500	210	36	48	66	100	140	195	280	380	490	730	730	1350*	1900*	3400*	3400*	6200*		
	1000	140	24	32	44	66	93	135	200	255	365	490	490	1000	1400	2330	2330	4210*	6270*	
	750	105	18	24	33	50	71	100	150	210	275	370	370	790	1050	1760	1760	3170	4730	6700*
8	1500	188	32	44	62	91	125	180	255	350	450	660	920	1300	1750*	3070*	3070*	5600*		
	1000	125	22	30	41	60	85	125	180	245	335	450	680	950	1270	2120	2120	3820	5700*	
	750	94	16	22	31	46	65	92	135	190	250	340	520	710	950	1590	1590	2870	4270	6070
9	1500	167	29	40	56	83	130	185	225	320	450	580	820	1100	1500	2740*	2740*	5000*		
	1000	111	19	27	38	56	86	125	160	215	300	430	620	800	1120	1890	1890	3400	5070*	
	750	83	15	20	28	43	67	95	125	170	235	340	500	650	900	1470	1470	2750	4020	5760
10	1500	150	25	35	50	74	100	150	210	280	390	540	760	1050	1420	2540*	2540*	4590*		
	1000	100	17	24	33	49	68	95	145	195	265	360	540	750	1000	1700	1700	3060	4560*	
	750	75	13	18	25	37	50	80	110	155	210	280	420	600	800	1320	1320	2460	3600	5160
11.2	1500	134	22	32	45	66	95	140	180	250	330	480	680	900	1250	2270	2270	4090*		
	1000	89	15	21	30	45	65	95	130	175	245	360	500	680	940	1530	1530	2750	4320	
	750	67	11	16	22	35	49	72	95	130	185	270	400	500	720	1180	1180	2200	3220	4610
12.6	1500	120	21	29	40	55	80	110	170	225	320	430	640	850	1200	2020	2020	3630*	5420*	
	1000	80	14	19	27	37	52	77	115	165	220	300	450	600	850	1390	1390	2600	3800	
	750	60	11	15	20	28	42	58	88	125	165	225	330	450	640	1050	1050	1950	2860	4090
14	1500	107	18	26	35	48	68	100	150	205	280	380	550	710	950	1790	1790	3230*	4820*	
	1000	71	12	17	24	32	46	70	105	145	195	265	400	520	710	1240	1240	2310	3380	
	750	53	9	13	18	24	35	52	78	110	145	200	290	420	560	930	930	1730	2530	3630
16	1500	94	15	22	30	43	60	90	135	185	250	340	490	650	860	1590	1590	2870	4270*	
	1000	62	10	15	20	29	40	62	92	130	175	235	350	490	650	1100	1100	2050	3000	
	750	47	8	11	15	22	32	47	69	97	130	175	270	370	500	820	820	1540	2250	3220
18	1500	83	13	19	27	37	55	73	120	140	220	310	430	550	740	1470	1470	2570	4020	
	1000	56	8.5	14	19	25	39	51	80	98	145	230	320	410	540	970	970	1820	2730	
	750	41	6.5	10	15	19	30	40	62	77	110	180	250	340	440	770	770	1440	2140	3110
20	1500	75		17	24	35	49	73	110	140	210	280	410	520	700	1320	1320	2460	3600	
	1000	50		12	17	23	33	49	74	98	140	190	280	380	500	880	880	1640	2400	
	750	38		9	12	18	25	38	58	77	110	145	230	310	400	700	700	1290	1920	2780
22.4	1500	67			21	30	41	65	99	135	185	250	390	490	660	1180	1180	2020	3110	
	1000	45			14	20	27	44	66	92	125	170	260	350	460	790	790	1360	2100	
	750	33			11	16	21	34	52	70	98	130	200	280	370	620	620	1040	1600	2370
Nominal Transmission ratio i_n	Input Speeds [rpm] n_1	Size of gear unit																		
		110	125	140	160	180	200	225	250	280	315	355	400	450	500	560	630	710	800	
Thermal capacity, PG1 (kW), for gear boxes without cooling																				
6.3 to 14	1500	30	40	48	62	80	40	122	155	205	245	300	390	480	630	780	1000	1200	1500	
	1000	26	35	46	55	72	35	120	150	190	240	290	380	470	620	770	980	1180	1470	
	750	23	32	40	53	67	32	110	142	180	230	285	370	460	610	760	950	1160	1450	
16 to 22.4	1500	25	34	42	56	73	40	120	147	185	240	290	380	465	610	760	970	1170	1470	
	1000	22	29	36	48	61	35	108	132	175	230	280	360	460	560	740	955	1150	1450	
	750	20	25	33	42	56	32	100	122	162	212	275	345	440	550	730	940	1130	1420	
Thermal capacity, PG2 (kW), for gear boxes with fan cooling																				
16 to 14	1500	52	65	82	110	135	162	205	260	320	405	500	650	800	1000	1300	1600	1)		
	1000	40	50	65	85	105	145	180	220	280	370	450	580	730	920	1200	1500	1)		
	750	32	42	58	75	100	130	170	210	260	340	420	530	680	880	1150	1400	1)	1)	
16 to 22.4	1500	45	58	75	95	120	155	200	250	290	390	490	630	780	950	1200	1600	1)		
	1000	34	44	55	70	95	120	160	210	270	350	440	570	700	900	1100	1500	1)		
	750	30	38	50	62	85	105	140	180	240	300	400	520	650	850	1000	1400	1)	1)	
Thermal capacity, PG3 (kW), for gear boxes with fan cooling coil																				
16 to 22.4	1500	148	165	186	202	225	248	267	295	345	390	450	540	680	830	880	1100	1)		
	1000	136	156	181	195	217	237	260	290	340	380	440	520	660	800	870	1080	1)		
	750	121	140	162	188	207	230	250	282	330	370	425	510	645	780	860	1050	1)	1)	
Thermal capacity, PG4 (kW), for gear boxes with fan and cooling coil																				
6.3 to 22.4	1500	170	190	220	250	280	310	350	400	460	550	650	800	1000	1200	1400	1700	1)		
	1000	150	170	200	225	250	290	320	360	430	510	600	720	920	1100	1300	1600	1)		
	750	130	150	180	210	240	270	310	350	410	480	560	670	860	1050	1250	1500	1)	1)	

For power ratings indicated in heavy type a check of the thermal capacity is always necessary (see the example of a calculation). At normal type print this is necessary only at an ambient temperature deviating from 20°C. The nominal gear ratings P_n [kW] marked with* require forced feed lubrication by a pump. The nominal transmission ratio is maintained with a tolerance of about ± 3% Intermediate transmission ratios are possible.

FOR MILL DUTY APPLICATIONS IT IS RECOMMENDED TO GO WITH FLS 1) Thermal rating on request

Three Stage Helical Gear Units - GHC

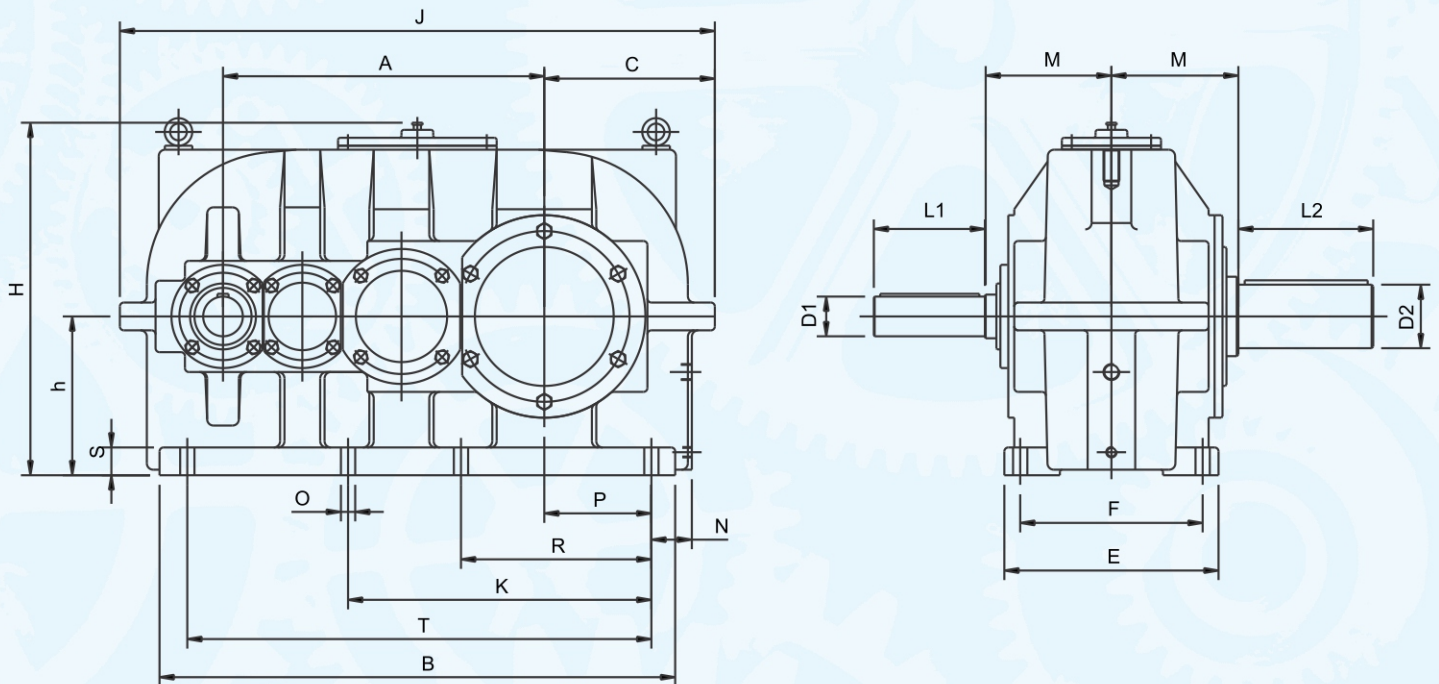

Size	$i_n \leq 22-50$		$i_n \leq 55-70$		$i_n \leq 100$		OUTPUT SHAFT				
	D1	L1	D1	L1	D1	L1	D2	L2	V2	Y2	OIL
140	30	80	25	60	20	50	60	120	18	64.4	8
160	35	80	30	80	25	60	70	140	20	75	10
180	40	100	35	80	30	80	80	160	22	85.5	14
200	45	100	40	100	35	80	90	180	25	95.5	18
225	50	110	45	100	40	100	100	200	28	106.4	24
250	55	120	50	110	45	100	110	210	28	116.4	28
280	60	140	55	120	50	110	100	210	28	106.4	30

Size	A	B	C	E	F	h	H	J	K	M	N	O	P	R	S	T
140	340	560	180	240	190	160	364	655		141.5	32.5	14	98	178	30	495
160	370	595	192	250	210	180	404	690		150	30	18	115	210	35	535
180	405	650	215	270	230	200	435	750		160	35.5	18	135	240	35	585
200	455	710	242	300	250	225	500	834		175	35	23	145	255	40	640
225	500	775	260	325	270	250	541	900		190	35	23	165	290	45	705
250	555	860	290	380	310	280	580	1000		210	40	27	180	315	45	780
280	650	1080	340	460	365	315	657	1200	598	200	75	27	200	343	50	930

Nominal Transmission ratio i_n	Nominal Speeds [rpm]		Size of gear unit															
	n_1	n_2	160	180	200	225	250	280	315	355	400	450	500	560	630	710	800	
14	1500	107	50	70	105	140	200	280	380	500	660	930	1810*	2540*	3270*	4880*		
	1000	71	34	74	73	95	135	190	270	390	500	700	1250	1770	2340	3420*	4900*	
	750	53	26	36	55	74	105	150	215	300	390	580	940	1330	1760	2580	3700	
16	1500	94	46	65	95	130	180	260	350	460	600	860	1610*	2260*	2910*	4330*	4390*	
	1000	62	32	44	66	88	120	170	250	350	460	640	1120	1580	2090	3060*	4390*	
	750	47	24	33	50	68	95	135	200	270	360	530	830	1180	1560	2280	3270	
18	1500	83	42	62	85	120	160	230	320	420	550	800	1490*	2110*	2790*	4080*	3900*	
	1000	56	30	42	60	80	105	150	220	320	420	560	1000	1410	1860	2720*	3900*	
	750	41	22	32	45	62	85	120	170	250	330	480	780	1110	1460	2170	3140	
20	1500	75	39	59	73	105	145	205	295	385	500	740	1320*	1860*	2460*	3600*	3440*	
	1000	50	27	39	54	70	98	140	200	290	380	550	880	1240	1640	2400*	3440*	
	750	38	20	30	43	55	77	110	160	240	305	445	690	990	1290	1920	2770	
22.4	1500	67	35	52	66	93	130	185	270	350	480	700	1170*	1640*	2170*	3180*	3040*	
	1000	45	24	35	50	65	91	130	190	265	345	520	780	1100	1450	2120	3040*	
	750	33	18	26	38	49	69	96	140	215	275	400	620	880	1140	1710	2460	
25	1500	60	30	44	62	83	115	160	235	330	450	660	1030*	1460*	1930*	2820*	2900*	
	1000	40	20	30	42	57	80	110	165	255	315	460	730	1040	1350	2010	2900*	
	750	30	15	22	31	43	60	85	125	195	240	350	550	780	1010	1510	2180	
28	1500	54	27	40	56	75	105	145	215	310	405	590	910*	1290*	1700*	2440*	2550*	
	1000	36	18	27	38	52	72	100	150	230	285	420	640	910	1190	1770	2550*	
	750	27	14	20	28	39	54	77	115	165	215	315	490	690	890	1330	1920	
31.5	1500	48	24	33	48	69	95	130	200	290	385	560	820*	1170*	1540*	2260*	2310*	
	1000	32	16	22	33	46	63	87	130	200	255	370	580	820	1070	1600	2310*	
	750	24	13	17	25	34	49	65	100	150	190	280	440	620	810	1200	1740	
35.5	1500	42	22	32	46	62	87	120	180	280	345	500	770	1100*	1430*	2120*	3070*	
	1000	28	15	22	30	41	58	82	120	185	230	340	510	720	950	1410	3070*	
	750	21	11	16	23	31	43	61	90	140	175	250	385	550	710	1060	1530	
40	1500	38	20	30	43	56	78	110	160	240	310	450	700	990	1290	1920*	2770*	
	1000	25	14	21	28	37	52	72	105	165	205	300	465	660	860	1280	1850	
	750	19	10	15	22	29	41	56	82	125	155	230	350	495	640	960	1390	
45	1500	33.5	17	26	36	50	69	97	145	220	275	400	620	880	1150*	1710*	2480*	
	1000	22	12	17	25	33	46	64	95	150	180	265	455	640	760	1140	1650	
	750	16.6	8.5	13	18	26	36	50	74	115	140	205	320	455	600	880	1260	
50	1500	30	15	23	32	44	62	87	130	200	245	360	550	780	1030	1540*	2220*	
	1000	20	11	15	22	31	43	60	87	135	165	240	365	520	690	1020	1480	
	750	15	8	12	16	23	32	44	65	100	120	180	290	410	540	780	1130	
56	1500	27	14	20	28	39	55	77	115	175	220	320	500	700	920	1370	1980*	
	1000	18	9.5	14	19	27	38	53	77	120	145	215	340	485	640	930	1330	
	750	13.4	7	10	15	21	28	40	59	91	110	165	255	360	475	690	990	
63	1500	24	11	17	23	35	45	63	100	150	195	285	440	630	810	1220	1760	
	1000	16	7.5	11	16	24	30	43	69	105	130	190	300	430	560	820	1180	
	750	12	6	8.5	12	18	23	32	52	78	98	145	230	325	430	630	900	
71	1500	21	9.5	15	21	31	40	56	90	135	175	250	395	560	730	1090	1570	
	1000	14	6.5	10	14	22	27	39	61	92	115	170	270	380	500	730	1050	
	750	10.5	5	7.5	11	16	20	29	46	69	86	125	200	285	380	550	790	
80	1500	18.8	8.5	14	19	29	36	51	82	120	155	230	350	495	640	690	1390	
	1000	12.5	6	9	13	19	24	34	54	82	100	150	240	340	450	650	940	
	750	9.4	4.5	7	10	14	19	27	40	63	76	110	180	255	340	495	700	
90	1500	16.7	8	12	17	26	32	46	74	110	140	205	320	455	600	880	1260	
	1000	11.1	5.5	8	11	17	22	31	49	74	92	135	210	300	395	570	820	
	750	8.3	4	6.5	9	13	17	24	37	57	69	100	160	225	295	430	620	
100	1500	15	9.5	16	24	30	44	60	95	130	175	290	410	540	780	1130	1130	
	1000	10	6.5	11	16	21	30	40	63	86	115	190	270	360	520	750	750	
	750	7.5	5	8	12	16	22	30	47	65	87	145	205	270	395	560	560	
112	1500	13.4	15	21	29	40	53	84	115	155	255	360	475	690	990	990	990	
	1000	8.9	10	14	19	27	36	57	78	105	170	245	325	470	670	970	970	
	750	6.7	7.5	11	15	20	27	43	65	98	130	215	295	415	595	855	1130	
Nominal transmission ratio i_n	Input Speeds [rpm] n_1	Size of gear unit																
		160	180	200	225	250	280	315	355	400	450	500	560	630	710	800		
6.3 to 14	1500	Thermal capacity, PG1 (kW), for gear boxes without cooling																
	1000	42	53	65	90	108	132	172	212	265	335	405	510	650	790	1010		
	750	39	48	60	80	98	125	168	202	255	330	400	490	630	760	990		
16 to 22.4	1500	36	48	60	80	97	122	165	202	255	330	395	495	630	770	990		
	1000	32	44	55	70	88	112	155	192	243	310	375	475	605	740	960		
	750	30	40	50	65	80	100	135	172	222	295	368	468	595	720	940		
16 to 14	1500	Thermal capacity, PG2 (kW), for gear boxes with fan cooling																
	1000	75	90	110	140	170	220	270	340	420	520	640	800	1050	1)	1)		
	750	65	83	100	130	160	205	250	320	380	492	590	750	1002	1)	1)		
16 to 22.4	1500	61	78	95	125	152	196	240	305	362	470	560	710	960	1)	1)		
	1000	72	88	106	138	162	205	260	324	387	500	590	755	1000	1)	1)		
	750	63	80	95	128	153	195	245	305	360	466	552	700	942	1)	1)		
16 to 22.4	1500	Thermal capacity, PG3 (kW), for gear boxes with fan cooling coil																
	1000	100	120	140	170	200	250	288	360	430	545	640	750	850	1)	1)		
	750	96	115	132	160	195	245	280	348	425	535	615	720	820	1)	1)		
6.3 to 22.4	1500	133	157	185	220	262	338	386	488	585	730	875	1040	1250	1)	1)		
	1000	122	150	172	210	257	325	362	466	550	697	805	980	1192	1)	1)		
	750	120	144	167	200	252	318	360	450	540	673	777	940	1145	1)	1)		

For power ratings indicated in heavy type a check of the thermal capacity is always necessary (see the example of a calculation). At normal type print this is necessary only at an ambient temperature deviating from 20°C. The nominal gear ratings P_n [kW] marked with* require forced feed lubrication by a pump. The nominal transmission ratio is maintained with a tolerance of about ± 3%. Intermediate transmission ratios are possible.

FOR MILL DUTY APPLICATIONS IT IS RECOMMENDED TO GO WITH FLS 1) Thermal rating on request

Four Stage Helical Gear Units - GHD

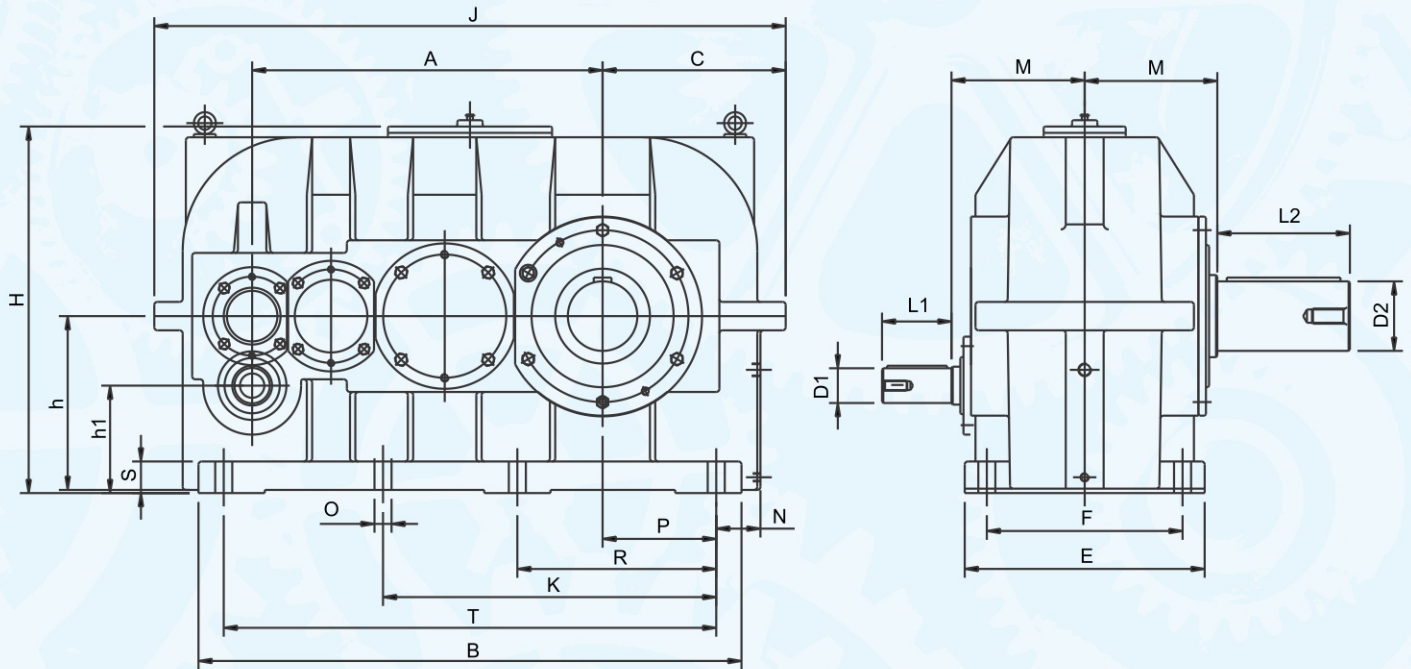

Size	$i_n \leq 112-250$		$i_n \leq 280-400$		$i_n \leq 630$		OUTPUT SHAFT				
	D1	L1	D1	L1	D1	L1	D2	L2	V2	Y2	OIL
225	28	60	25	60	20	50	100	200	28	106	24
250	30	80	25	60	20	50	110	210	28	116	28
280	35	80	30	80	25	60	100	210	28	106	30

Size	A	B	C	E	F	h1	h	H	J	K	M	N	O	P	R	S	T
225	500	775	260	325	270	150	250	541	900		190	35	23	165	290	45	705
250	555	860	290	380	310	170	280	580	1000		210	40	27	180	315	45	780
280	650	1080	340	460	365	190	315	657	1200	598	200	75	27	200	343	50	930

Nominal Transmission ratio i_n	Nominal Speeds [rpm] n_1, n_2		Size of gear unit											
			225	250	280	315	355	400	450	500	560	630	710	800
112	1500	13.4	20	29	40	59	91	110	160	255	360	480	690	990
	1000	8.9	14	20	27	39	59	70	105	170	240	320	470	670
	750	6.7	10	15	20	29	43	53	83	130	185	235	355	500
125	1500	12	18	26	36	52	81	97	145	230	320	425	610	880
	1000	8	12	17	32	34	53	64	95	155	210	285	420	570
	750	6	9	13	18	26	40	48	71	115	160	210	310	440
140	1500	10.7	16	23	32	46	72	87	130	205	290	380	550	800
	1000	7.15	11	16	21	31	47	58	85	135	190	250	365	520
	750	5.4	8	12	16	23	36	44	65	100	145	190	275	395
160	1500	9.37	14	20	26	41	63	76	115	180	255	340	495	710
	1000	6.25	9.5	14	18	27	42	51	75	120	170	225	330	470
	750	4.68	7.5	10	14	21	32	39	58	91	130	170	250	360
180	1500	8.34	13	19	25	37	57	69	100	160	225	295	435	630
	1000	5.56	8.5	12	17	25	38	46	68	105	150	200	290	420
	750	4.17	6.5	9.5	13	18	29	35	51	81	115	155	220	320
200	1500	7.5	12	15	22	33	51	62	92	145	205	270	395	560
	1000	5	8	10	14	22	34	41	61	96	135	180	260	375
	750	3.75	6	8	11	17	26	30	44	72	100	135	200	280
224	1500	6.7	10	14	19	29	45	55	82	130	185	240	355	500
	1000	4.47	7	9	13	20	30	37	54	86	120	160	235	340
	750	3.35	5	7	10	15	23	28	41	65	92	120	175	255
250	1500	6	9.5	12	17	26	40	48	71	115	165	215	315	450
	1000	4	6	8.5	12	17	27	32	48	77	110	145	210	300
	750	3	4.5	6.5	9	13	20	24	36	58	82	110	155	225
280	1500	5.35	8	11	15	23	36	44	65	100	145	190	275	395
	1000	3.57	5.5	7.5	10	15	24	29	43	67	95	125	185	265
	750	2.67	4	5.5	8	12	18	22	32	50	71	95	140	195
315	1500	4.76	7.5	9.5	13	21	32	39	58	91	130	170	250	355
	1000	3.17	5	6.5	9	14	21	25	37	60	86	115	165	235
	750	2.38	3.5	5	7	10	16	20	29	46	65	86	125	180
355	1500	4.23	6.5	8.5	12	18	29	35	51	82	115	155	225	320
	1000	2.82	4.5	6	8.5	12	19	23	34	53	75	99	145	205
	750	2.12	3	4.5	6.5	9.5	14	17	25	41	58	77	110	160
400	1500	3.75	6	8	11	16	26	31	45	71	100	135	195	280
	1000	2.5	4	5	7.5	11	17	20	30	48	68	90	130	190
	750	1.88	3	4	5.5	8	13	15	23	35	52	66	98	135
450	1500	3.33	5	7.5	10	13	21	29	39	65	92	120	175	255
	1000	2.22	3.5	5	6.5	9	14	19	26	43	60	81	115	170
	750	1.66	2.5	3.5	5	6.5	11	14	19	32	46	60	88	125
500	1500	3		6.5	9	12	19	26	35	58	82	110	155	225
	1000	2		4.5	6	8	13	17	23	38	54	72	105	150
	750	1.6		3	4.5	6	9.5	13	17	29	41	54	79	115
560	1500	2.68			8	11	17	23	30	50	71	95	140	195
	1000	1.78			5.5	7	11	16	21	35	49	65	94	135
	750	1.34			4	5.5	8.5	12	16	26	37	49	71	100
630	1500	2.38				9.5	15	21	28	48	65	86	125	180
	1000	1.59				6.5	10	14	18	30	43	57	83	120
	750	1.19				5	7.5	10	14	23	33	43	63	90

Nominal transmission ratio i_n	Input Speeds [rpm] n_1	Size of gear unit												
		225	250	280	315	355	400	450	500	560	630	710	800	
Thermal capacity, PG1 (kW), for gear boxes without cooling														
112 to 630	1500	0	38	50	66	90	105	135	170	210	275	360	430	550
	1000	0	35	45	55	80	95	120	150	200	255	340	410	530
	750	0	30	40	53	74	90	110	140	180	225	290	385	490

For power ratings indicated in heavy type a check of the thermal capacity is always necessary (see the example of a calculation). At normal type print this is necessary only at an ambient temperature deviating from 20°C. The nominal gear ratings P_{G2} [kW] and dimensions for gears with fan cooling on request. The nominal transmission ratio is maintained with a tolerance of about ± 3%. Intermediate transmission ratios are possible.

GP SERIES (TWO STAGE) HELICAL GEAR BOX

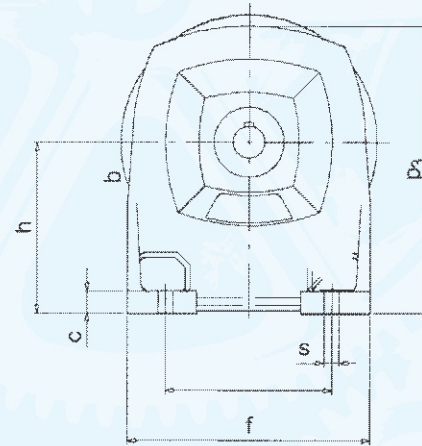
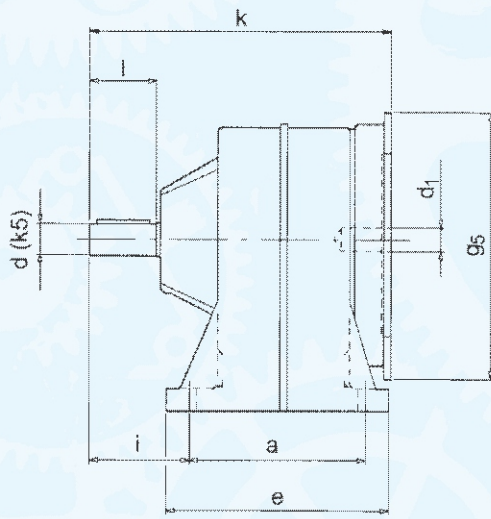

Model	Weight (kg)	d1	g5	k	a	b	c	e	f	h	i	p3	s	d	l
GP 102	11	14	160	181	106	100	13	134	150	102	60	176	9	19	40
	10	19	200	225											
GP 128	17	14	160	207	126	118	16	160	178	128	74	215	11	24	50
	17	19	200	225											
	17	24	200	242											
GP 142	24	19	200	253	145	130	18	179	196	142	95	237	11	28	60
	24	24	200	270											
	24	28	250	312											
GP 162	39	19	200	338	205	160	21	245	226	162	120	269	14	38	80
	39	24	200	338											
	39	28	250	341											
GP 160	50	28	250	409	270	195	24	310	276	160	137	319	13	48	110
	50	28	250	409											
	54	38	300	435											

Model : GP 102		
Ratio	HP	RPM
44.6	0.5	32
34.8		41
28.4		50
22.4		64
17.1		84
14.2		101
12		120
9.4		152
7.23	0.5/1.0	199
6.05	1.0	238
4.6		312

Model : GP 128		
Ratio	HP	RPM
33.4	1.0	42
27.5		52
23.09		62
20.64		70
18.65		77
16.8		85
13.8		104
11.5		125
9.68	1.0/2.0	149
7.05		204
5.94		242
4.8		300

Model : GP 142		
Ratio	HP	RPM
36.3	1.0/2.0	39
28.2		51
22.6		63
18.6	1.5/2.0	77
15		96
11.4		126
9.1	0.5/2.0 / 3.0	158
7.2		199
5.8		249
4.7		304

Model : GP 162		
Ratio	HP	RPM
32.3	2.0/3	45
25.4		57
22.7	3.0	63
18.9		76
13.4		107
11.4	3.0/5.0	126
10.5		137
9.4		153
5.8		248
4.7		306

Model : GP 160		
Ratio	HP	RPM
37	5.0	38
27		53
19.2		75
18.9		76
14.8	7.5/5.5	97
10.7		135
8.2		176
6.3		229
4.6		313
4.7		306

M-SERIES (THREE STAGE) HELICAL GEAR BOX

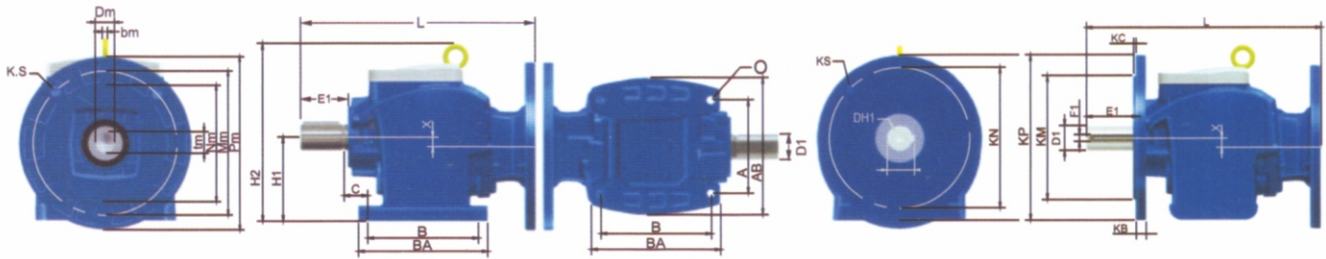

MODEL	MOTOR TYPE	DIMENSIONS (MM)																								
		NM	MM	PM	DM	TM	BM	L	B	BA	A	AB	O	H1	H2	C	D1	E1	F1	DH1	KP	KM	KN	KS	KC	KB
MODEL M:12	P71 B-5	110	130	160	14	16.5	5	244	105	127	90	135	9	85	155	20	25	50	8	8	140	95	115	9	3	10
	P80 B-5	130	165	200	19	22	6	244	105	127	90	135	9	85	155	20	25	50	8	8	140	95	115	9	3	10
	P71 B-14	70	85	105	14	16.5	5	244	105	127	90	135	9	85	155	20	25	50	8	8	140	95	115	9	3	10
MODEL M:21	P71 B-5	110	130	160	14	16.5	5	276	130	155	110	165	11	100	194	25	30	60	8	10	200	130	165	11	4	12
	P80 B-5	130	165	200	19	22	6	276	130	155	110	165	11	100	194	25	30	60	8	10	200	130	165	11	4	12
	P80 B-5	130	165	200	24	28	8	276	130	155	110	165	11	100	194	25	30	60	8	10	200	130	165	11	4	12
MODEL M:30	P80 B-5	130	165	200	19	22	6	340	165	200	135	210	14	115	240	30	35	70	10	12	200	130	165	11	4	12
	P90 B-5	130	165	200	24	28	8	340	165	200	135	210	14	115	240	30	35	70	10	12	200	130	165	11	4	12
	P100 B-5	180	215	250	28	32	8	340	165	200	135	210	14	115	240	30	35	70	10	12	250	180	215	14	4	15
	P112 B-5	180	215	250	28	32	8	340	165	200	135	210	14	115	240	30	35	70	10	12	250	180	215	14	4	15
MODEL M:60	P80 B-5	130	165	200	19	22	8	380	195	225	150	240	14	135	265	30	40	80	12	16	200	130	165	11	4	12
	P90 B-5	130	165	200	24	28	8	380	195	225	150	240	14	135	265	30	40	80	12	16	200	130	165	11	4	12
	P100 B-5	180	215	250	28	32	8	380	195	225	150	240	14	135	265	30	40	80	12	16	250	180	215	14	4	15
	P112 B-5	180	215	250	28	32	8	380	195	225	150	240	14	135	265	30	40	80	12	16	250	180	215	14	4	15
MODEL M:85	P90 B-5	130	165	200	24	28	8	400	205	235	170	250	17	140	290	35	50	100	14	16	250	180	215	14	4	19
	P100 B-5	180	215	250	28	32	8	400	205	235	170	250	17	140	290	35	50	100	14	16	250	180	215	14	4	19
	P112 B-5	180	215	250	28	32	8	400	205	235	170	250	17	140	290	35	50	100	14	16	250	180	215	14	4	19
	P132 B-5	230	265	300	38	42.5	12	410	205	235	170	250	17	140	290	35	50	100	14	16	300	230	265	14	4	19
MODEL M:150	P100 B-5	180	215	250	28	32	8	450	260	306	215	307	18	180	360	40	60	120	18	20	300	230	265	14	4	19
	P112 B-5	180	215	250	28	32	8	450	260	306	215	307	18	180	360	40	60	120	18	20	300	230	265	14	4	19
	P132 B-5	230	265	300	38	42.5	12	450	260	306	215	307	18	180	360	40	60	120	18	20	300	230	265	14	4	19

IN-PUT 1440 RPM																
RATIO	80:1	72:1	60:1	51.4:1	45:1	40:1	36:1	30:1	25:1	20:1	17.1	15:1	10:1	7.5:1	6:1	4.8:1
R.P.M	18	20	24	28	32	36	40	48	58	72	85	96	144	192	240	300
0.5 HP / 0.37 KW	21	21	21	12	12	12	12	12	12	12	12	12	12	12	12	12
0.75 HP / 0.55 KW	30	30	21	21	21	21	21	21	12	12	12	12	12	12	12	12
1 HP / 0.75 KW	30	30	30	21	21	21	21	21	21	21	12	12	12	12	12	12
1.5 HP / 1.1 KW	60	60	60	60	60	30	30	30	21	21	21	21	21	21	21	21
2 HP / 1.5 KW	85	85	60	60	60	60	60	30	30	30	30	21	21	21	21	21
3 HP / 2.2 KW	85	85	85	60	60	60	60	30	30	30	30	30	30	30	30	30
5 HP / 3.7 KW	150	150	150	150	85	85	85	85	85	85	60	60	60	30	30	30
7.5 / 5.5 KW	300	300	300	300	150	150	150	150	150	150	85	85	85	85	85	85
10 HP / 7.5 KW	-	-	-	300	300	300	300	150	150	150	150	85	85	85	85	85

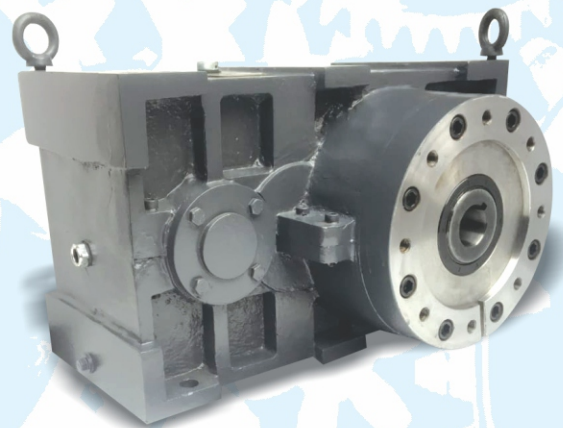
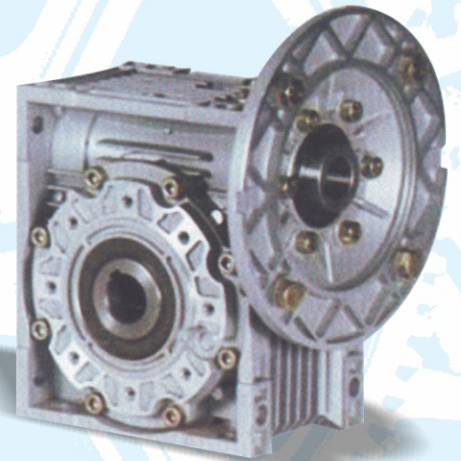
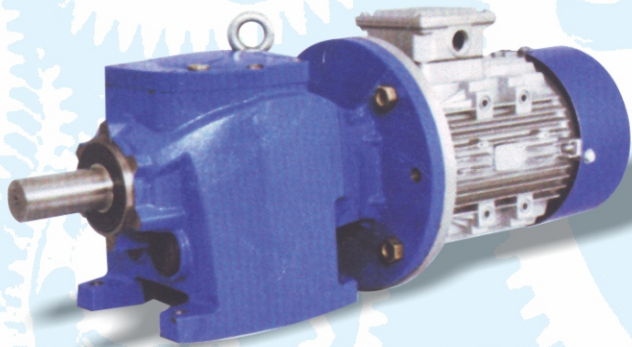

Since 1991

GOVARDHAN GEAR

E-mail : govardhan_gear@yahoo.in, govardhan.gear@gmail.com

Jeegar V. Patel

M. : 94266 47917

Priyank B. Patel

M. : 94293 47917