

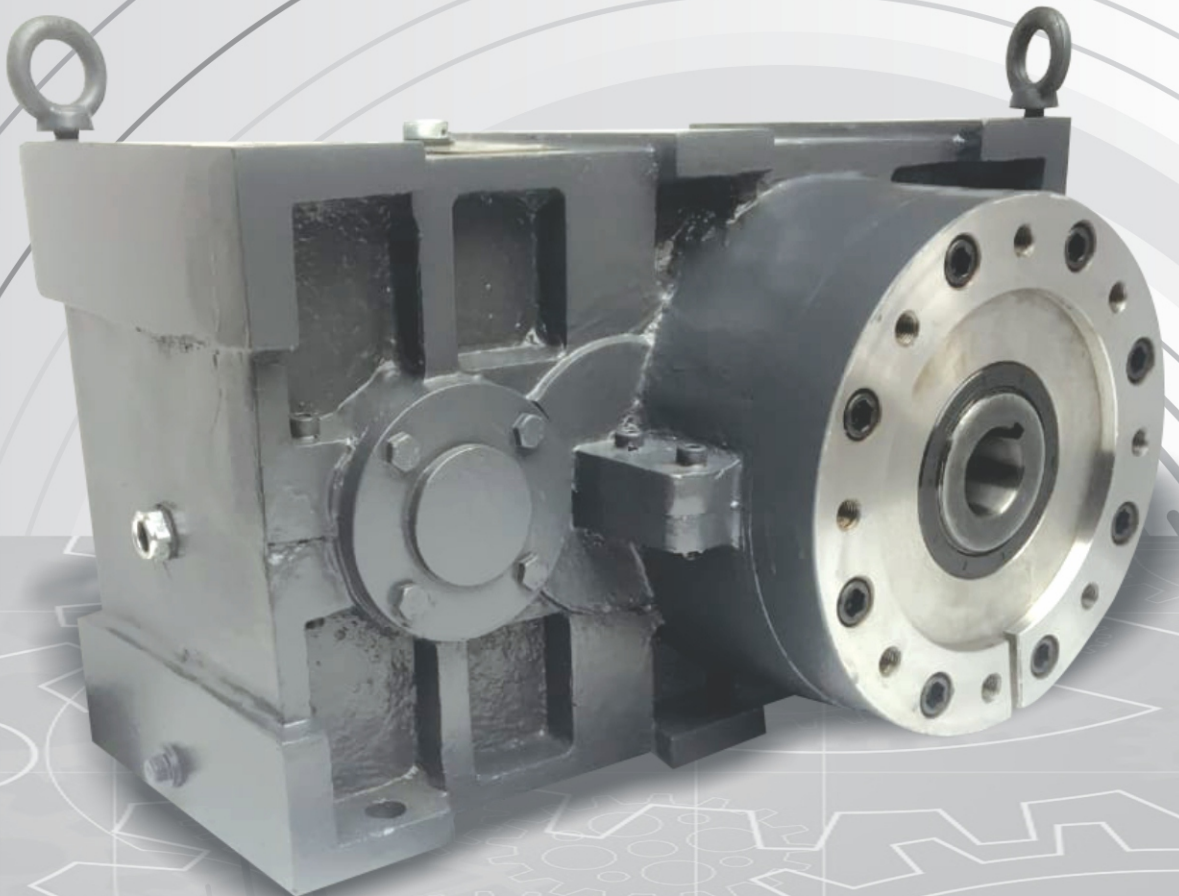

Extruder Helical Gear Units

GEAR BOX



Extruder Helical Gear Units

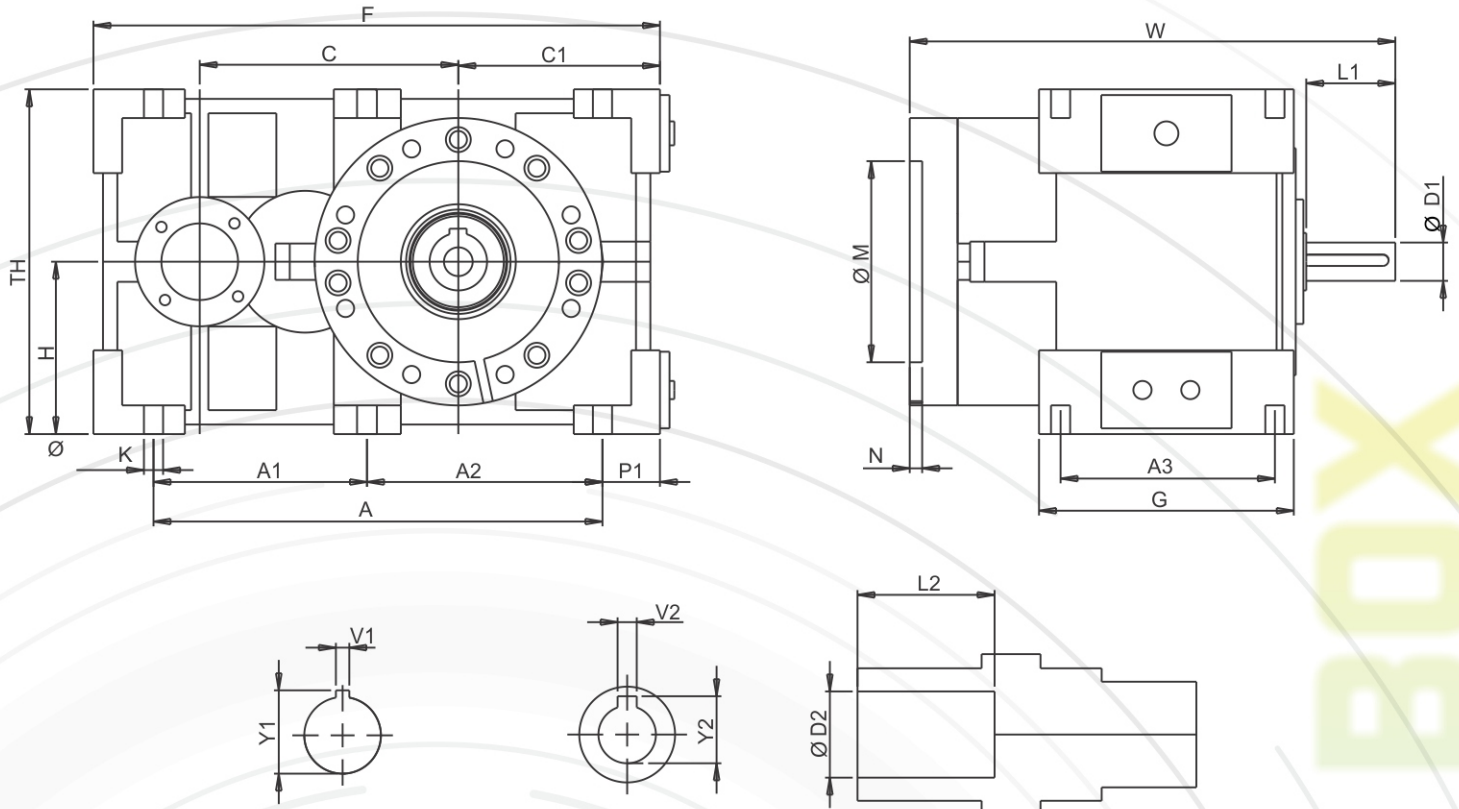

GEAR BOX HOUSING DIMENSION

TYPE	C	C1	A	A1	A2	A3	P1	G	H	TH	F	W	K
110	190	150	328	-	-	149	47	210	125	249	420	391	14
125	215	160	365	-	-	173	52	223	143	285	461	410	16
140	240	177	431	-	-	195	49	238	156	312	535	455	18
160	270	207	468	222	246	221	62	269	181	361	600	520	20
180	305	235	531	264	266	233	74	285	210	420	685	571	22

Type	INPUT SHAFT				OUTPUT SHAFT				MOUNTING SIZE					THRUST BEARING	WEIGHT	OIL
	D1	L2	V1	Y1	D2	L2	V2	Y2	M	N	R	T	S			
110	25	60	8	28	35	120	10	40	120	8	185	M-16	8	29414	103	6
125	30	60	8	33	40	130	12	43.5	150	10	205	M-16	8	29416	125	7
140	35	80	10	38.5	50	135	14	54	210	10	245	M-16	8	29418	173	8
160	40	100	12	43	60	150	18	64.5	210	10	255	M-20	8	29420	250	12
180	50	110	14	53.5	70	170	20	75	220	10	285	M-20	8	29424	325	18

Extruder Helical Gear Units

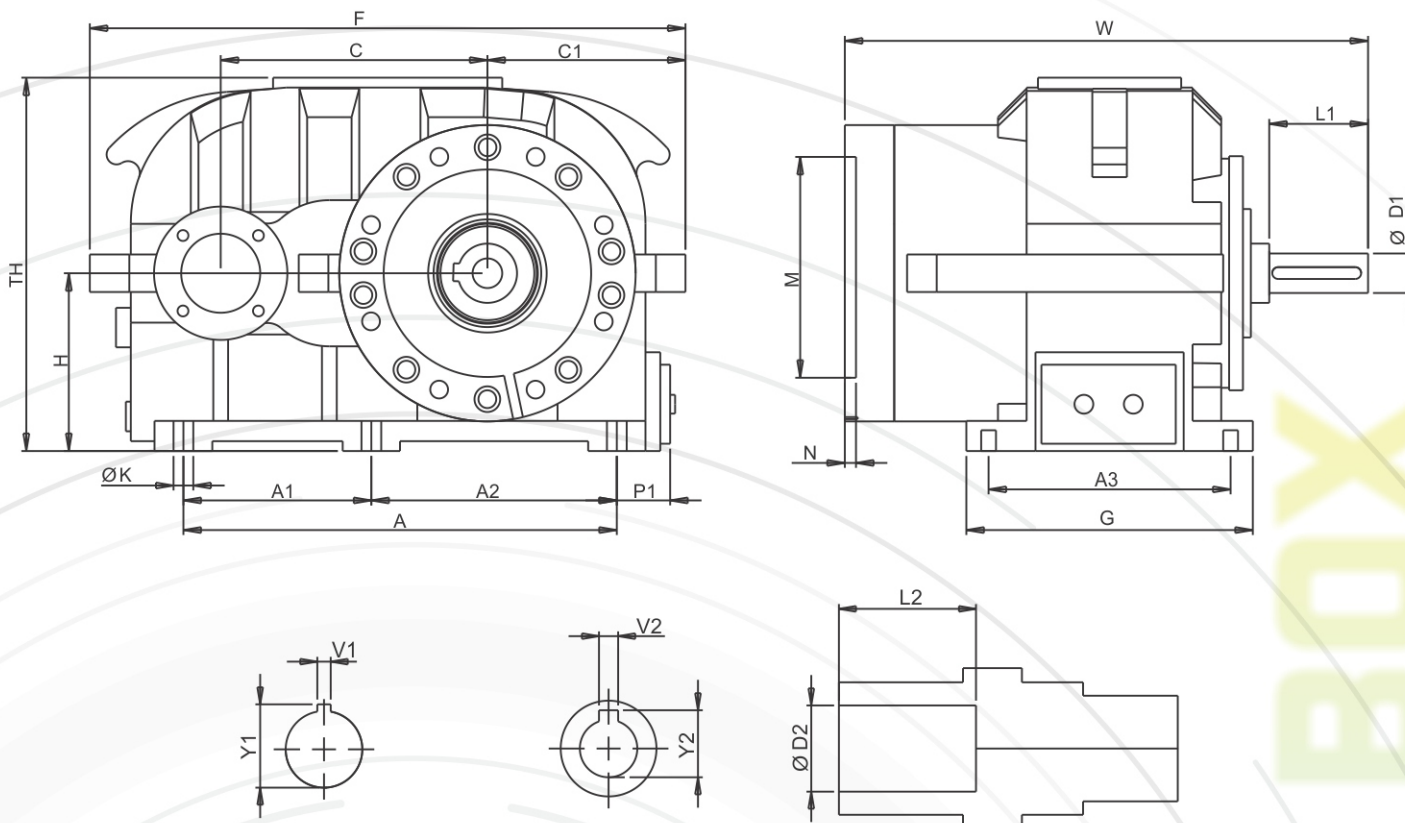

GEAR BOX HOUSING DIMENSION

TYPE	C	C1	A	A1	A2	A3	P1	G	H	TH	F	K
200	340	250	570	265	305	270	35	320	225	500	770	22
225	385	260	635	345	290	290	40	350	250	555	825	23
250	430	292	761	345	416	350	40	430	280	615	930	27

Type	INPUT SHAFT				OUTPUT SHAFT				MOUNTING SIZE					THRUST BEARING	WEIGHT
	D1	L2	V1	Y1	D2	L2	V2	Y2	M	N	R	T	S		
200	55	110	16	59	85	180	22	91	270	11	325	M-20	8	29426	460
225	60	120	18	64	110	180	28	116.5	275	12	340	M-20	10	29430	675
250	70	140	20	74.5	120	190	32	127.5	340	12	410	M-24	10	29434	900



MODEL	THRUST BEARING	MAXIMUM . H.P	MAXIMUM SCREW SIZE
110	29414	10	35
125	29414	15	45
140	29418	20	65
160	29420	30	75
180	29424	50	100
200	29426	60	110
225	29430	90	125
250	29434	120	150

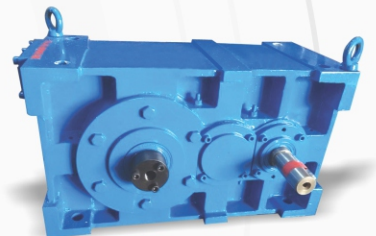
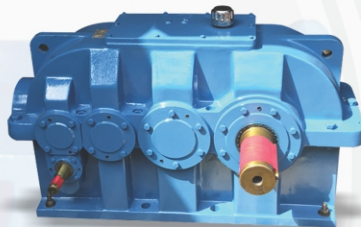
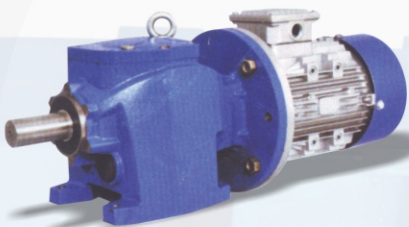
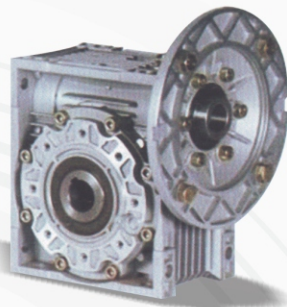

Since 1991

GOVARDHAN GEAR

3/1, Dashrathbhai Estate, Nr. Shakriba Party Plot,
C.T.M. Char Rasta, Ahmedabad-380026.

E-mail : govardhan_gear@yahoo.in Mob. : 9426607917

E-mail : govardhan.gear@gmail.com

Jeegar V. Patel
M. : 94266 47917

Priyank B. Patel
M. : 94293 47917

